

Technical sheet :

M-X 70-2



Technical characteristics			Metric
1.1	Manufacturer		Manitou
1.2	Model Name		M-X 70-2
1.3	Power source		Diesel
1.4	Operator type		Seated
1.5	Max. capacity	Q	7000 kg
1.6	Load centre of gravity	c	600 mm
1.8	Load distance, centre of drive axle to fork	x	803 mm
1.9	Wheelbase	y	2.49 mm
Weight			
2.1	Service weight		9880 kg
2.2	Weight on front axle (laden) / rear axle (laden)		14954 kg / 1926 kg
2.3	Weight on front axle (Unladen) / rear axle (Unladen)		4040 kg / 5840 kg
Wheels			
3.1	Tyres type		Pneumatic
3.2	Dimensions of front wheels		18R185 8T N20XF
3.3	Dimensions of rear wheels		265/70R19,5 6T P30 HT3
3.5	Number of front wheels / rear wheels		2 / 2
3.5.2	Number of drive wheels		2
3.6	Front wheel gauge	b10	1700 mm
3.7	Rear wheel gauge	b11	1545 mm
Dimensions			
4.1	Tilt of Mast Forward (deg) / Backward (deg)	α / β	6 / 12
4.7	Height of overhead guard (cabin)	h6	2475 mm
4.8	Seat height/stand height	h7	1485 mm
4.12	Height of towing bar (coupling height)	h10	690 mm
4.19	Overall length	l1	5700 mm
4.20	Length to face of forks	l2	4200 mm
4.21	Overall width	b1	2155 mm
4.22	Forks section / width / length	s / e / l	70 mm x 150 mm / 1200 mm
4.23	Fork carriage ISO 2328 (class/form) A/B		FEM4
4.24	Fork carriage width	b3	1750 mm
4.31	Ground clearance below mast	m1	300 mm
4.32	Ground clearance at centre of wheelbase	m2	410 mm
4.34	Aisle width for 800 x 1200 pallet lengthways	Ast	6703 mm
4.35	Turning radius	Wa	4200 mm
4.36	Internal turning radius (over tyres)	b13	1000 mm
Performances			
5.1	Travel speed (laden)		24 km/h
5.2.1	Lifting speed (unladen)		0.4 m/s
5.3.1	Lowering speed (unladen)		0.4 m/s
5.5	Drawbar pull (Laden)		7960 daN
Engine			
7.1	Engine brand		Perkins

Dimensional drawing

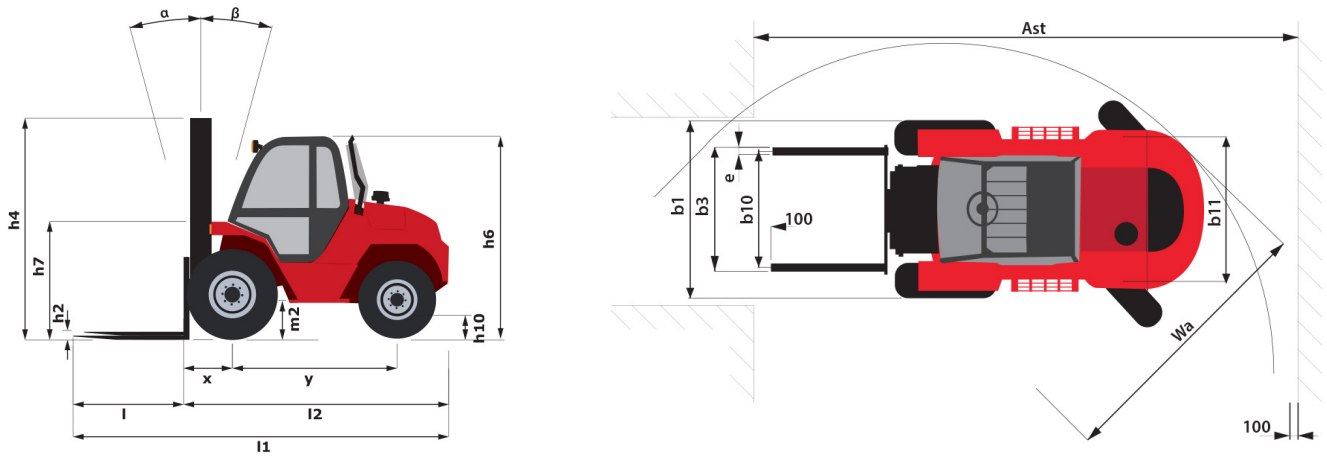

Characteristics of masts and residual capacities

Full Visibility Duplex		FVD 36	FVD 40	FVD 45
h3 - Lifting Height	mm	3600	4000	4500
α / β - Mast inclination (front / rear)	°	15 / 15	15 / 15	15 / 15
Residual capacity without attachment (Industrial load chart)	kg	7000	7000	5000
Residual capacity with integrated side shift (Industrial load chart)	kg		6350	3850

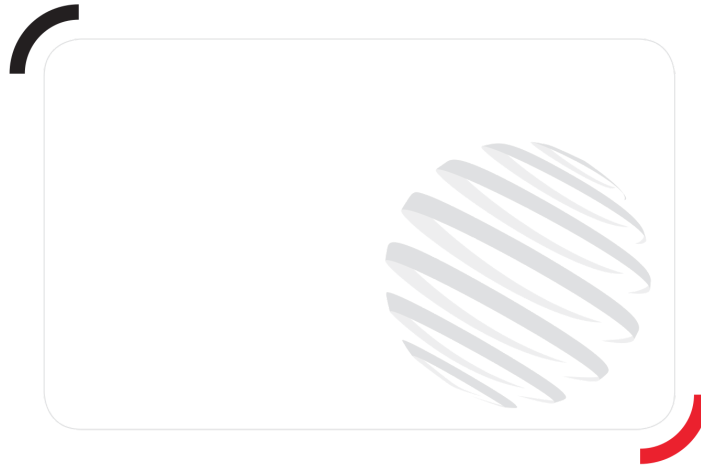

Siège Social

430 rue de l'Aubinière - 44150 Ancenis Cedex - France

Tel: +33(0)2 40 09 10 11 - Fax: +33 (0)2 40 09 10 97

www.manitou.com



This brochure describes versions and configuration options for Manitou products which may be fitted with different equipment. The equipment described in this brochure may be standard, optional or not available depending on version. Manitou reserves the right to change the specifications shown and described at any time and without prior warning. The manufacturer is not liable for the specifications given. For more information, contact your Manitou dealer. Non-contractual document. Product descriptions may differ from actual products. List of specifications is not comprehensive. The logos and visual identity of the company are the property of Manitou and may not be used without authorisation. All rights reserved. The photos and diagrams contained in this brochure are provided for information only.

MANITOU BF SA - Limited company with board of directors - Share capital: 39,668,399 euros - 857 802 508 RCS Nantes