

Technical sheet :

MC-X 18-2



	Technical characteristics		Metric
1.1	Manufacturer		Manitou
1.2	Model Name		MC-X18-2
1.3	Power source		Diesel
1.4	Operator type		Seated
1.5	Max. capacity	Q	1800 kg
1.6	Load centre of gravity	c	500 mm
1.8	Load distance, centre of drive axle to fork	x	616 mm
1.9	Wheelbase	y	1900 mm
	Weight		
2.1	Service weight		3405 kg
2.2	Weight on front axle (laden) / rear axle (laden)		4200 kg / 1005 kg
2.3	Weight on front axle (Unladen) / rear axle (Unladen)		1625 kg / 1780 kg
	Wheels		
3.1	Tyres type		Pneumatic
3.2	Dimensions of front wheels		12.5/80 - 18/12 SL R4
3.3	Dimensions of rear wheels		7.00-12/12 ED PLUS
3.5	Number of front wheels / rear wheels		2 / 2
3.5.2	Number of drive wheels		2
3.6	Front wheel gauge	b10	1159 mm
3.7	Rear wheel gauge	b11	1112 mm
	Dimensions		
4.1	Tilt of Mast Forward (deg) / Backward (deg)	α / β	10 / 12
4.7	Overall height of low overhead guard (Buggie version)	h6*	1990 mm
4.8	Seat height/stand height	h7	1034 mm
4.19	Overall length	l1	4100 mm
4.20	Length to face of forks	l2	2950 mm
4.21	Overall width	b1	1450 mm
4.22	Forks section / width / length	s / e / l	35 mm x 100 mm / 1150 mm
4.23	Fork carriage ISO 2328 (class/form) A/B		2A
4.24	Fork carriage width	b3	1260 mm
4.31	Ground clearance below mast	m1	300 mm
4.32	Ground clearance at centre of wheelbase	m2	320 mm
4.35	Turning radius	Wa	2585 mm
	Performances		
5.1	Travel speed (laden / unladen)		12 km/h / 24.9 km/h
5.2	Lifting speed (laden / unladen)		0.4 m/s / 0.4 m/s
5.3	Lowering speed (laden / unladen)		0.4 m/s / 0.4 m/s
5.5	Drawbar pull (Laden / Unladen)		1050 daN / 1100 daN
5.7	Gradeability (laden / unladen)		21 % / 34 %
5.10	Service brake		Hydraulic
	Engine		
7.1	Engine brand / model		Kubota / V1505
7.2	Engine power according to ISO 1585		27 kW
7.3	Rated speed		3000 rpm
7.4	Number of cylinders / Capacity of cylinders		4 - 1498 cm ³
7.5	Fuel consumption according to VDI cycle		3.6 l/h
	Miscellaneous		
8.1	Type of drive control		Cable
8.2	Working hydraulic pressure for attachments		180 Bar
8.3	Oil flow rate for attachments		37 l/min
8.4	Measured/guaranteed mean noise level at the ear of the operator		< 79 dB(A)

Dimensional drawing

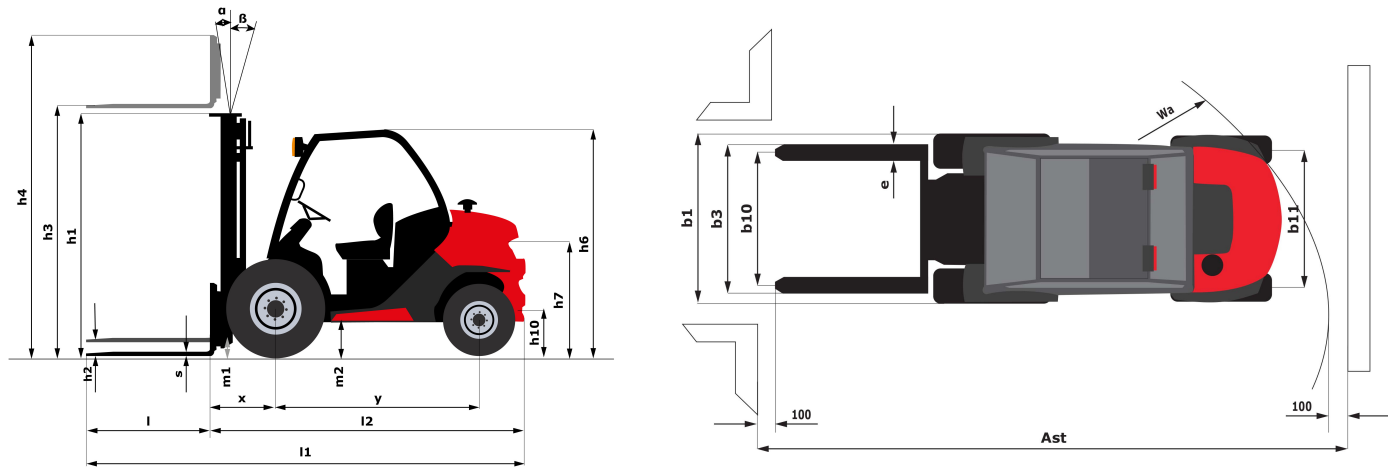

Characteristics of masts and residual capacities

Full Visibility Duplex		FVD 33	FVD 37	FVD 40	FVD 45
h1 - Height mast lowered *	mm	2348	2608	2798	3048
h2 - Free lift	mm	85	85	85	85
h3 - Lifting Height	mm	3300	3700	4000	4500
h4 - Height mast extended *	mm	4018	4428	4768	5268
α / β - Mast inclination (front / rear)	°	10 / 12	10 / 12	10 / 12	10 / 12
Residual capacity at max height	kg	1800			
Height at max capacity	mm	3300			
Residual capacity without attachment (Industrial load chart)	kg	1800			

Free Lift Triplex		FLT 37	FLT 43	FLT 47	FLT 55
h1 - Height mast lowered *	mm	1998	2198	2348	2608000
h2 - Free lift	mm	1305	1505	1655	1915
h3 - Lifting Height	mm	3700	4300	4700	5500000
h4 - Height mast extended *	mm	4453	5053	5453	6253000
α / β - Mast inclination (front / rear)	°	10 / 12	10 / 12	10 / 12	6 / 6

Full Visibility Triplex		FVT 33
h1 - Height mast lowered *	mm	1888
h2 - Free lift	mm	135
h3 - Lifting Height	mm	3300
h4 - Height mast extended *	mm	4048
α / β - Mast inclination (front / rear)	°	10 / 12



Siège Social

430 rue de l'Aubinière - 44150 Ancenis Cedex - France

Tel: +33(0)2 40 09 10 11 - Fax: +33 (0)2 40 09 10 97

www.manitou.com



This brochure describes versions and configuration options for Manitou products which may be fitted with different equipment. The equipment described in this brochure may be standard, optional or not available depending on version. Manitou reserves the right to change the specifications shown and described at any time and without prior warning. The manufacturer is not liable for the specifications given. For more information, contact your Manitou dealer. Non-contractual document. Product descriptions may differ from actual products. List of specifications is not comprehensive. The logos and visual identity of the company are the property of Manitou and may not be used without authorisation. All rights reserved. The photos and diagrams contained in this brochure are provided for information only.

MANITOU BF SA - Limited company with board of directors - Share capital: 39,668,399 euros - 857 802 508 RCS Nantes