

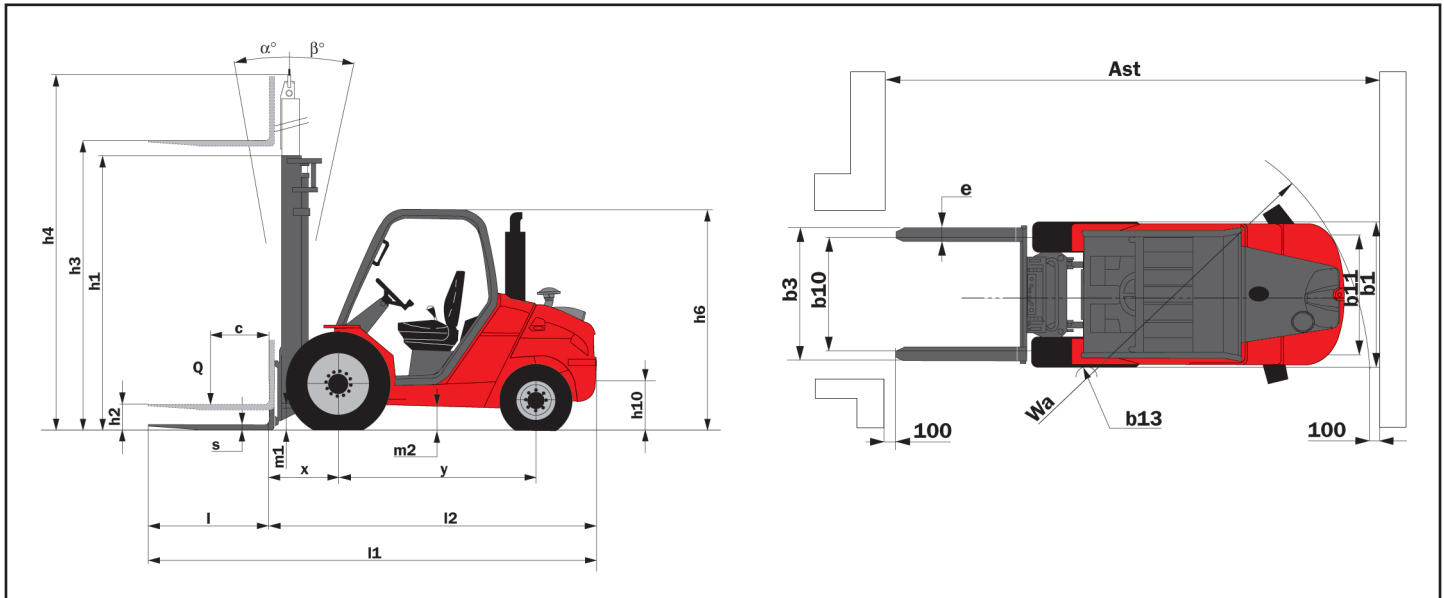

 **MANITOU**

				MANITOU	MANITOU	MANITOU	MANITOU
				MSI 20	MSI 25	MSI 30	MSI 35
		Q		2	2,5	3,0	3,5
		c		500	500	500	500
		x		625	625	630	630
		y		1800	1800	1800	1800
				3770	4070	4704	4845
				4911 / 859	5695 / 875	6782 / 922	7430 / 915
				1661 / 2109	1633 / 2437	1899/2805	1732/3113
				275/70 R22.5	275/70 R22.5	275/70 R22,5	275/70 R22,5
				7.00X12 14PR	7.00X12 14PR	7.00X12 14PR	7.00X12 14PR
				2 x 2	2 x 2	2 x 2	2 x 2
		b10		1046	1046	1046	1046
		b11		1102	1102	1102	1102
		$\alpha / \beta$		10 / 12	10 / 12	10/12	10/12
		h1		2300	2300	2300	2300
		h2		130	130	130	130
		h3		3300	3300	3300	3300
		h4		4131	4131	4193	4193
		h6		2105	2105	2105	2105
		h7		1025	1025	1025	1025
		h10		470	470	470	470
		l1		4045	4045	4080	4130
		l2		2945	2945	2980	3030
		b1		1323	1323	1323	1323
		s / e / l		40 / 100 / 1100	40 / 100 / 1100	40 / 100 / 1100	45 / 125 / 1100
		b3		1260	1260	1260	1260
		m1		270	270	270	270
		m2		260	260	260	260
		Ast		4425	4425	4425	4495
		Ast		4625	4625	4625	4695
		Wa		2600	2600	2635	2665
		b13		150	150	150	150
				20 / 20	20 / 20	20 / 20	20 / 20
				0.4 / 0.5	0.4 / 0.5	0,4 / 0,5	0,4 / 0,5
				0.6 / 0.5	0.6 / 0.5	0,5 / 0,4	0,4 / 0,3
				2280 / 1370	2280 / 1370	2460 / 1260	2640 / 1560
				33 / 37	31 / 32	24 / 29	29 / 29
				44	44	44	44
				2700	2700	2700	2700
				4/2434	4/2434	4/2434	4/2434
				140	170	185	190
				77	77	77	77
				82	82	82	82



MSI 2,0 & 2,5 T		MSI 2,0 & 2,5 T									MSI 2,0 & 2,5 T		
		DVT30	DVT33	DVT35	DVT37	DVT40	DVT45	DVT50	DVT55	DVT560	DLL30	DLL33	DLL35
h3*	mm	3000	3300	3500	3700	4000	4500	5000	5500	6000	3000	3300	3500
h1	mm	2150	2300	2400	2560	2750	3000	3250	3500	3790	2150	2300	2400
h2	mm	130	130	130	130	130	130	130	130	130	1393	1543	1643
h4	mm	3831	4131	4331	4531	4831	5331	5831	6331	6831	3797	4097	4297
	kg	2000	2000	2000	2000	2000	1800	1500	-	-	2000	2000	2000
	kg	2500	2500	2500	2500	2500	2200	1900	-	-	2500	2500	2500

MSI 2,0 & 2,5 T		MSI 2,0 & 2,5 T			MSI 2,0 & 2,5 T								
		DLL37	DLL40	DLL45	TLL37	TLL40	TLL43	TLL47	TLL50	TLL55	TLL60	TLL65	TLL70
h3*	mm	3700	4000	4500	3700	4000	4300	4700	5000	5500	6000	6600	7000
h1	mm	2560	2750	3000	1950	2050	2150	2300	2400	2560	2750	3000	3250
h2	mm	1803	1993	2243	1221	1321	1421	1571	1671	1831	2021	2271	2521
h4	mm	4497	4797	5297	4469	4769	5069	5469	5769	6269	6769	7269	7769
	kg	2000	2000	1500	2000	2000	2000	1700	1500	1300	1000	-	-
	kg	2500	2500	1900	2500	2500	2400	2100	1900	1500	1500	-	-

MSI 3,0 & 3,5 T		MSI 3,0 & 3,5 T									MSI 3,0 & 3,5 T		
		DVT30	DVT33	DVT35	DVT37	DVT40	DVT45	DVT50	DVT55	DVT560	DLL30	DLL33	DLL35
h3*	mm	3000	3300	3500	3700	4000	4500	5000	5500	6000	3000	3300	3500
h1	mm	2150	2300	2400	2560	2750	3000	3250	3500	3790	2150	2300	2400
h2	mm	135	135	135	135	135	135	135	135	135	1396	1546	1646
h4	mm	3893	4193	4393	4593	4893	5396	5863	6393	6893	3799	4099	4299
	kg	3000	3000	3000	3000	3000	2600	2400	1900	1500	3000	3000	3000
	kg	35000	3500	3500	3500	3400	3100	3000	-	-	3500	3500	3500

MSI 3,0 & 3,5 T		MSI 3,0 & 3,5 T			MSI 3,0 & 3,5 T								
		DLL37	DLL40	DLL45	TLL37	TLL40	TLL43	TLL47	TLL50	TLL55	TLL60	TLL65	TLL70
h3*	mm	3700	4000	4500	3700	4000	4300	4700	5000	5500	6000	6600	7000
h1	mm	2560	2750	3000	2050	2150	2300	2400	2560	2750	3000	3250	3500
h2	mm	1806	1996	2246	1297	1397	1547	1647	1807	1997	2247	2497	2747
h4	mm	4499	4799	5299	4500	4800	5100	5500	5800	6300	6800	7300	7800
	kg	3000	3000	2600	3000	3000	2800	2600	2400	1900	1500	-	-
	kg	3500	3400	2700	3400	3400	3100	2700	2500	2100	1800	1200	-

				MANITOU	MANITOU
				MH 20	MH 25
		Q		2000	2500
		c		500	500
		x		625	625
		y		1800	1800
				4050	4350
				5091 / 864	5812 / 948
				1841 / 2114	1750 / 2510
				280/80 R20 XMCL	280/80 R20 XMCL
				27,10 - 12 IC 30 14PR	27,10 - 12 IC 30 14PR
				4	4
		b10		1450	1450
		b11		1160	1160
		$\alpha / \beta$		10 / 12	10 / 12
		h1		1835	1835
		h2		-	-
		h3		3300	3300
		h4		4070	4070
		h6		1990	1990
		h7		1025	1025
		h10		470	470
		l1		4045	4045
		l2		2945	2945
		b1		1450	150
		s / e / l		40 / 100 / 1100	40 / 100 / 1100
		b3		1260	1260
		m1		270	270
		m2		260	260
		Ast		5090	5090
		Ast		5290	5290
		Wa		2500	2500
		b13		1080	1080
				14 / 14	14 / 14
				0,4 / 0,6	0,6 / 0,6
				0,6 / 0,5	0,6 / 0,5
				3550 / 2190	3550 / 2190
				57 / 52	50 / 48
				44	44
				1600	1600
				4/2434	4/2434
				125	125
				77	77
				81	81

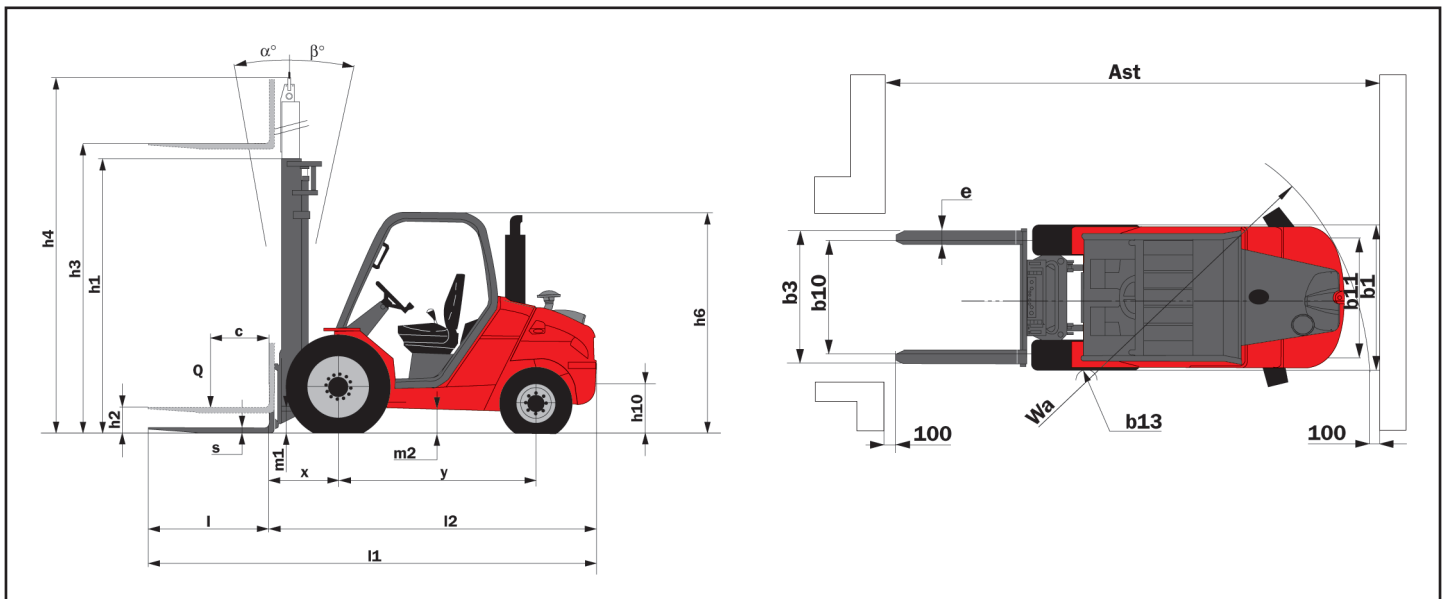

MH 2,0 & 2,5 T		DVT						
		DVT27	DVT30	DVT33	DVT35	DVT37	DVT40	DVT45
h3*	mm	2730	3030	3330	3530	3730	4030	4530
h1	mm	1995	2145	2295	2395	2555	2745	2995
h2	mm	130	130	130	130	130	130	130
h4	mm	3531	3831	4131	4331	4531	4831	5331
MH20	kg	2000	2000	2000	1800	1600	1500	1100
MH25	kg	2500	2500	2500	1900	1900	1550	1100

MH 2,0 & 2,5 T		DLL						TLL			
		DLL30	DLL33	DLL35	DLL37	DLL40	DLL45	TLL37	TLL40	TLL43	TLL47
h3*	mm	3040	3340	3540	3740	4040	4540	3740	4040	4340	4740
h1	mm	2145	2295	2395	2555	2745	2995	1945	2045	2145	2295
h2	mm	1388	1538	1638	1798	1988	2238	1216	1316	1416	1566
h4	mm	3797	4097	4297	4497	4797	5297	4469	4769	5069	5469
MH20	kg	2000	2000	1800	1600	1500	1100	1600	1500	1200	1000
MH25	kg	2500	2500	1900	1900	1550	1100	1900	1550	1250	1000

				<b>MANITOU</b>	<b>MANITOU</b>
				<b>MSI 40 T</b>	<b>MSI 50 T</b> -
		Q		4	5
		c		500	600
		x		691	701
		y		2075	2075
				6980	8420
				9245 / 1735	11467 / 1953
				3210 / 3770	3489 / 4931
				315/70 R22,5	315/70 R22,5
				225/75 R15	225/75 R15
				2x 2	2x 2
		b10		1420	1420
		b11		1142	1142
		α / β		10 / 12	10 / 12
		h1		2775	2775
		h2		-	-
		h3		3700	3700
		h4		4677	4672
		h6		2440	2440
		h7		1300	1300
		h10		540	540
		l1		4494	4584
		l2		3294	3384
		b1		1732	1732
		s / e / l		50 / 150 / 1200	60 / 150 / 1200
		b3		1670	1670
		m1		185	185
		m2		225	225
		Ast		4756	5041
		Ast		4956	5241
		Wa		2865	2950
		b13		125	125
				22 / 22	22 / 22
				0.6 / 0.6	0.5 / 0.5
				0.4 / 0.5	0.4 / 0.4
				3180 / 2020	3350 / 2420
				24 / 29	24 / 26
				55	55
				2200	2200
				4/3400	4/3400
				230	230
				103	103
				81	81

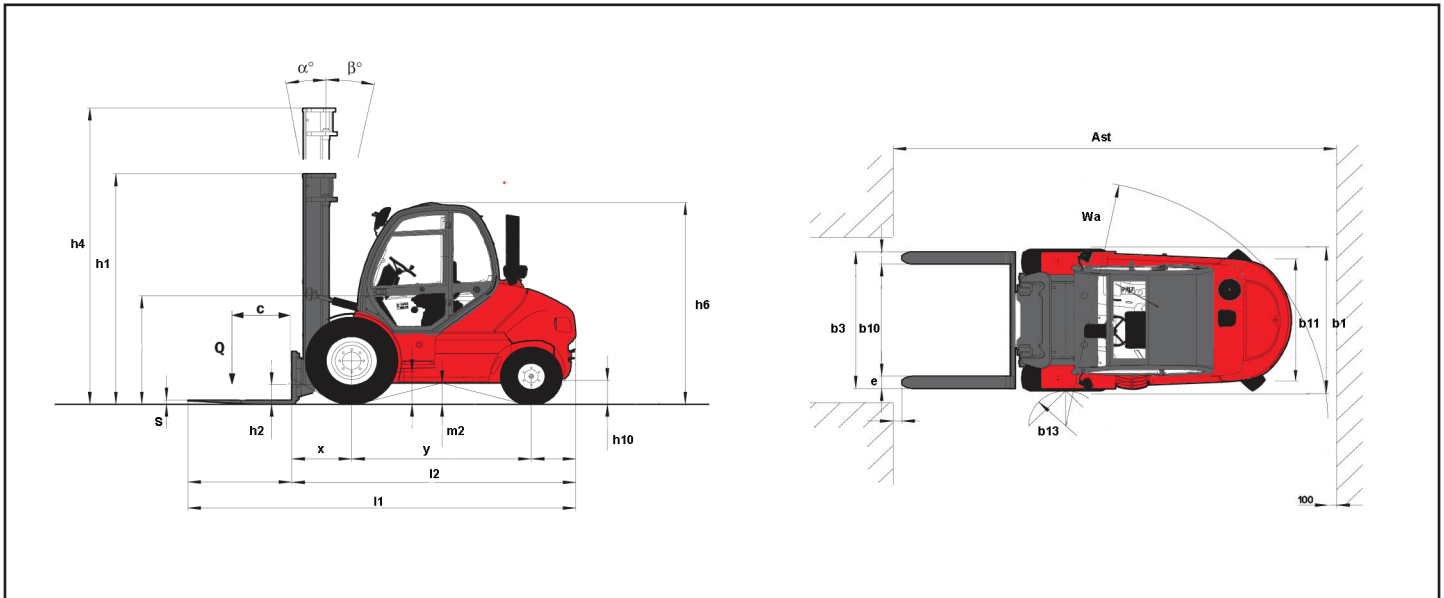

MSI 40 T CDG 500 mm													
			DVT30	DVT33	DVT35	DVT37	DVT40	DVT45	DVT50	DLL30	DLL33	DLL35	DLL37
h3*	mm	3000	3300	3500	3700	4000	4500	5000	3000	3300	3500	3700	4000
h1	mm	2425	2575	2675	2775	2925	3175	3425	2450	2600	2700	2800	2950
h2	mm	-	-	-	-	-	-	-	1532	1682	1782	1882	2032
h4	mm	3977	4277	4477	4677	4977	5477	5977	3968	4268	4468	4668	4968
	kg	4000	4000	4000	4000	4000	4000	4000	4000	4000	4000	4000	4000

MSI 40 T CDG 500 mm										
			TLL37	TLL40	TLL43	TLL45	TLL47	TLL50	TLL55	TLL60
h3*	mm	3700	4000	4300	4500	4700	5000	5500	6000	
h1	mm	2175	2275	2375	2450	2510	2625	2775	2950	
h2	mm	1258	1358	1458	1533	1593	1708	1858	2033	
h4	mm	4667	4967	5267	5467	5667	5967	6467	6967	
	kg	40000	4000	4000	4000	3800	3700	3500	3400	

MSI 50 T CDG 600 mm													
			DVT30	DVT33	DVT35	DVT37	DVT40	DVT45	DVT50	DLL30	DLL33	DLL35	DLL37
h3*	mm	3000	3300	3500	3700	4000	4500	5000	3000	3300	3500	3700	4000
h1	mm	2425	2575	2675	2775	2925	3175	3425	2450	2600	2700	2800	2950
h2	mm	-	-	-	-	-	-	-	1541	1691	1791	1891	2041
h4	mm	3972	4272	4472	4672	4972	5472	5972	3969	4269	4469	4669	4969
	kg	5000	5000	5000	5000	5000	4800	4800	5000	5000	5000	5000	5000

MSI 50 T CDG 600 mm										
			TLL37	TLL40	TLL43	TLL45	TLL47	TLL50	TLL55	TLL60
h3*	mm	3700	4000	4300	4500	4700	5000	5500	6000	
h1	mm	2175	2275	2375	2450	2510	2625	2775	2950	
h2	mm	1263	1363	1463	1538	1598	1713	1863	2038	
h4	mm	4662	4962	5262	5462	5662	5962	6462	6962	
	kg	4900	4900	4900	4800	4600	4400	3800	3100	

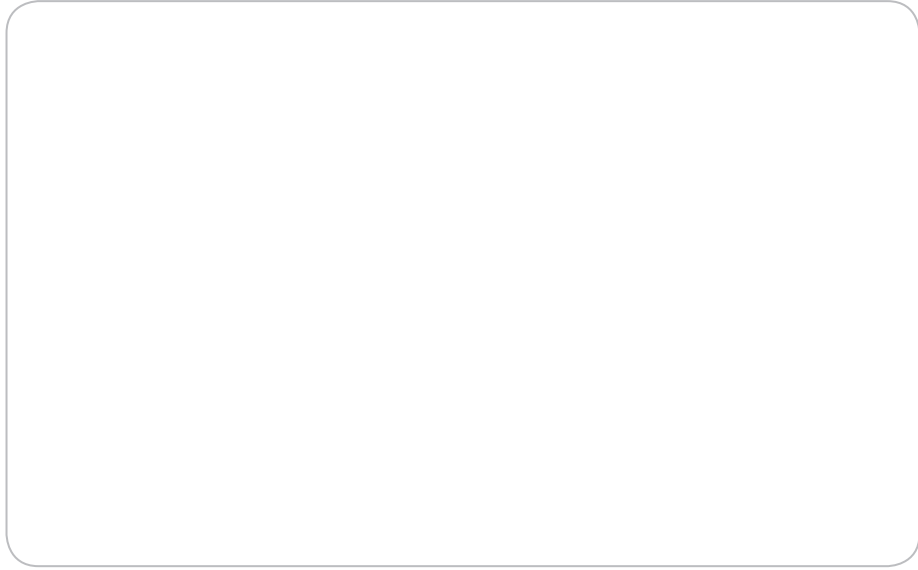

 **MANITOU**