

MLT-X735-120 PS

TECHNICAL DATA SHEET



MLT-X735-120 PS

MLT-X 735-120 PS	
Lifting capacity at 500 mm from fork heels	3500 kg
Break-out force	4200 daN
Lifting height	6.90m
Time: laden/unladen (in sec)	
Lifting	6.70/7.30
Lowering	4.80/4.60
Extension	7.10/7.30
Retraction	5.70/5.50
Crowd	2.00
Dump	2.30
Tyres	460/70 R24
Forks	
Length x width x thickness	1200 x 125 x 45 mm
Carriage rotation	146°
Braking	multiple-disk brake with oil bath on front and rear axles
PERKINS STAGE III A engine	1104E-44TA
Cubic capacity	4 cyl. Turbo/4400 cm ³
Power at 2200 rpm (ISO/TR 14396)	124 HP/91 kW
Max. torque at 1400 rpm (ISO/TR 14396)	490 Nm
Injection	direct
Cooling	water
Transmission	torque converter
Gearbox	Powershift
Number of gears (forward/reverse)	6/3
Max. travel speed	40 kph*
Hydraulics	150 l/min - 270 bar
Piston pump	electronically controlled variable cubic capacity
Control valve	DDIC
Capacities	
Hydraulic oil	135 l
Fuel	120 l
Unladen weight (with forks)	7250 kg
Width overall	2.40 m
Height overall	2.30 m
Length overall	4.87 m
Turning radius (outer wheels)	3.77 m
Ground clearance	0.44 m
Drawbar pull	up to 8770 daN
Noise at driving position (LpA)	79 dB
Environmental noise (LWA)	106 dB
Vibration to whole hand/arm	< 2.5 m/s ²

mm	D2 4165	I 789	P3 53°	V1 1310
A 1200	E 5990.4	J 980	R 3685	V2 3918.5
B 2810	F 1935	K 1260	S 7714.9	W 2402
C 1191.4	F1 1935	L 45	T 3575	Y 12.5°
C1 1287	G 450	N 1715	U1 2295	Z 133.7°
D 4790.4	G1 435	O 125	U2 2545	
D1 4886	G2 435	P2 38°	V 4885	

Maximum height reach: 1.03 m

As per standard EN 1459 annex B

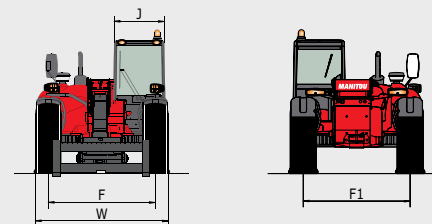
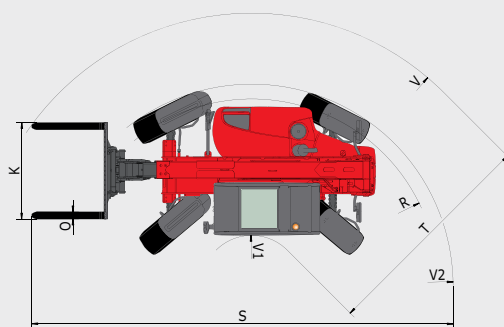
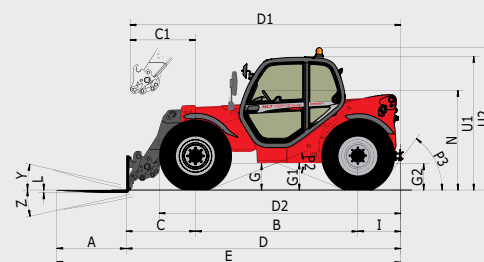
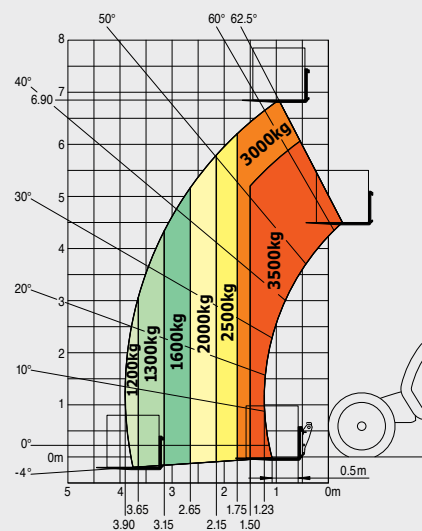

This brochure describes versions and configuration options for Manitou products which may be fitted with different equipment. The equipment described in this brochure may be standard, optional or not available depending on version. Manitou reserves the right to change the specifications shown and described at any time and without prior warning. The manufacturer is not liable for the specifications given. For more information, contact your Manitou dealer. Non-contractual document. Product descriptions may differ from actual products. List of specifications is not comprehensive. The logos and visual identity of the company are the property of Manitou and may not be used without authorisation. All rights reserved. The photos and diagrams contained in this brochure are provided for information only.

MANITOU BF SA - Limited company with board of directors - Share capital: 39,547,824 euros - 857 802 508 RCS Nantes



* May vary according to applicable regulations

FT107EN_B_0315_MLTX735_120PS