

Technical sheet :

MC-X 30-2



Technical characteristics			Metric
1.1	Manufacturer		Manitou
1.2	Model Name		MC-X30-2
1.3	Power source		Diesel
1.4	Operator type		Seated
1.5	Max. capacity	Q	3000 kg
1.6	Load centre of gravity	c	500 mm
1.8	Load distance, centre of drive axle to fork	x	626 mm
1.9	Wheelbase	y	1900 mm
Weight			
2.1	Service weight		4355 kg
2.2	Weight on front axle (laden) / rear axle (laden)		6435 kg / 920 kg
2.3	Weight on front axle (Unladen) / rear axle (Unladen)		1660 kg / 2695 kg
Wheels			
3.1	Tyres type		Pneumatic
3.2	Dimensions of front wheels		12,5/80-18/12 SL R4
3.3	Dimensions of rear wheels		7,00-12/12 ED PLUS
3.5	Number of front wheels / rear wheels		2 / 2
3.5.2	Number of drive wheels		2
3.6	Front wheel gauge	b10	1159 mm
3.7	Rear wheel gauge	b11	1176 mm
Dimensions			
4.1	Tilt of Mast Forward (deg) / Backward (deg)	α / β	10 / 12
4.7	Height of overhead guard (cabin)	h6	2155 mm
4.7	Overall height of low overhead guard (Buggie version)	h6*	1990 mm
4.8	Seat height/stand height	h7	1094 mm
4.19	Overall length	l1	4265 mm
4.20	Length to face of forks	l2	3085 mm
4.21	Overall width	b1	1450 mm
4.22	Forks section / width / length	s / e / l	45 mm x 122 mm / 1150 mm
4.23	Fork carriage ISO 2328 (class/form) A/B		3A
4.24	Fork carriage width	b3	1260 mm
4.31	Ground clearance below mast	m1	300 mm
4.32	Ground clearance at centre of wheelbase	m2	310 mm
4.35	Turning radius	Wa	2650 mm
Performances			
5.1	Travel speed (laden / unladen)		12 km/h / 24.9 km/h
5.2	Lifting speed (laden / unladen)		0.47 m/s / 0.46 m/s
5.3	Lowering speed (laden / unladen)		0.5 m/s / 0.3 m/s
5.5	Drawbar pull (Laden / Unladen)		1810 daN / 1150 daN
5.7	Gradeability (laden / unladen)		23 % / 26 %
5.10	Service brake		Hydraulic brakes by loss of pressure
Engine			
7.1	Engine brand / model		Kubota / V2403
7.2	Engine power according to ISO 1585		36 kW
7.3	Rated speed		2700 rpm
7.4	Number of cylinders / Capacity of cylinders		4 - 2434 cm ³
7.5	Fuel consumption according to VDI cycle		5.3 l/h
Miscellaneous			
8.1	Type of drive control		Cable
8.2	Working hydraulic pressure for attachments		180 Bar
8.3	Oil flow rate for attachments		53 l/min
8.4	Measured/guaranteed mean noise level at the ear of the operator		< 82 dB(A)

Dimensional drawing

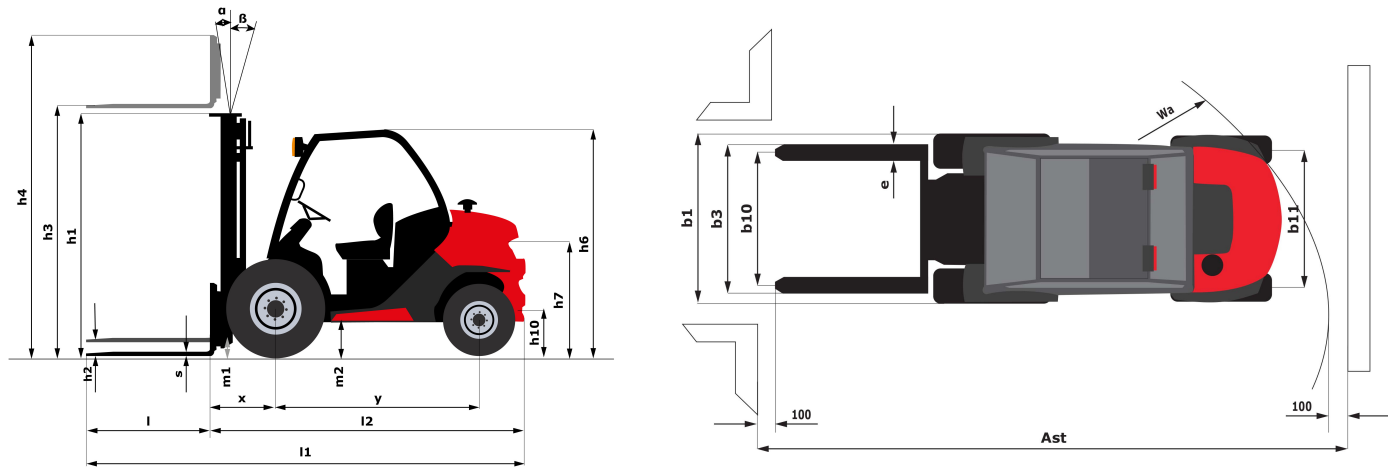

Characteristics of masts and residual capacities

Full Visibility Duplex		FVD 45
h1 - Height mast lowered *	mm	3038
h2 - Free lift	mm	117
h3 - Lifting Height	mm	4500
h4 - Height mast extended *	mm	5290
α / β - Mast inclination (front / rear)	°	10 / 12

Free Lift Triplex		FLT 34	FLT 37	FLT 40	FLT 43	FLT 47	FLT 55
h1 - Height mast lowered *	mm	1988	1988	2188	2338	2438	2788
h2 - Free lift	mm	1235	1335	1435	1585	1685	2035
h3 - Lifting Height	mm	3400	3700	4000	4300	4700	5500
h4 - Height mast extended *	mm	4236	4536	4836	5136	5536	6336
α / β - Mast inclination (front / rear)	°	10 / 12	10 / 12	10 / 12	10 / 12	10 / 12	6 / 6
Residual capacity at max height	kg	1580					
Height at max capacity	mm	2500					
Residual capacity without attachment (Industrial load chart)	kg	1580					

Full Visibility Triplex		FVD 33	FVD 37	FVT 33
h1 - Height mast lowered *	mm	2338	2598	1878
h2 - Free lift	mm	117	117	129
h3 - Lifting Height	mm	3300	3700	3300
h4 - Height mast extended *	mm	4090	4490	4079
α / β - Mast inclination (front / rear)	°	10 / 12	10 / 12	10 / 12



Siège Social

430 rue de l'Aubinière - 44150 Ancenis Cedex - France

Tel: +33(0)2 40 09 10 11 - Fax: +33 (0)2 40 09 10 97

www.manitou.com



This brochure describes versions and configuration options for Manitou products which may be fitted with different equipment. The equipment described in this brochure may be standard, optional or not available depending on version. Manitou reserves the right to change the specifications shown and described at any time and without prior warning. The manufacturer is not liable for the specifications given. For more information, contact your Manitou dealer. Non-contractual document. Product descriptions may differ from actual products. List of specifications is not comprehensive. The logos and visual identity of the company are the property of Manitou and may not be used without authorisation. All rights reserved. The photos and diagrams contained in this brochure are provided for information only.

MANITOU BF SA - Limited company with board of directors - Share capital: 39,668,399 euros - 857 802 508 RCS Nantes